

**Replace fresnel lens according to the corresponding models and parts taking into account the following table:**

Model Fresnel	Lens Diameter	Part Number
50-01	80mm	50-01/L1
50-02	120mm	50-02/L1
50-03	150mm	50-03/L1
50-04	250mm	50-04/L1
50-05	300mm	50-05/L1
50-06	175mm	50-06/L1
50-07	175mm	50-07/L1



**DEXEL S.R.L.**

Av. General Paz 13130

C1440FJX Buenos Aires - Argentina

Phone: (5411) 4687-3001

Fax: (5411) 4687-7550

email: [info@dexel.com](mailto:info@dexel.com) [www.dexel.com](http://www.dexel.com)

# Fresnels Projectors

**MODELS 50-01, 50-02, 50-03, 50-04, 50-05, 50-06 & 50-07  
MODELS 50-01PO, 50-02PO, 50-03PO, 50-04PO, 50-05PO,  
50 06PO & 50-07PO**



## Operating Instructions

**Version MI-FR-2005-1**



## 7- Power supply

The projector has been designed for a maximum voltage of 240 Volts. The supply cable complies with the standard IEC 60245. Furthermore, the user must make sure that the ground is always connected.

**WARNING: Always connect the projector to a mains protected by a suitable electric fuse selected according to the instructions provided for by the manufacturer of the lamp to be used.**

### WARNING!

The electric conductors have the following color codes:

Green and Yellow:	Ground
Blue:	Neutral
Brown:	Live

If the colors of the electric wires do not match the colors marked for their identification in the connector terminals, try the following: the green and yellow wire must be connected to the terminal marked with the "E" letter or to the ground symbol, or green or green and yellow color. The Blue wire must be connected to the terminal marked with the "N" letter or black color. The brown connector must be connected with the letter "V" or "L" or red color.

**Use 16 Amp, connector/terminal box (Except for model 50-05 a 32 Amp connector/terminal box must be used)** Fixed and removable electric connections: Connect the electric conductor to the appropriate connector following the instructions mentioned above.

The terminal box must be firmly fixed and mounted in order to sustain 6,5mm between any point of the terminal box and the metal parts of the boxes when being installed.

**THE GROUND MUST BE CONNECTED TO USE THIS PRODUCT!**

## 2- General Characteristics

The projector you have acquired is in compliance with the 73/23/EEC directives as well as with the European standards EN 60598-1 and EN 60598-2-17. The label located on one of the sides of the projector provides the following information:

- Model
  - Maximum supply voltage (V) of the projector.
  - Maximum power of the projector in (W).
  - Maximum temperature of the environment admitted in C°.
  - Maximum temperature of the projector body in C°.
  - Minimum distance from any inflammable surface.
  - Information to find the 0° position of the projector when the tip of the arrow points upwards.
  - Maximum angle of inclination upwards and downwards.
- These limits are set by the manufacturer of the lamp used. These limits should not be exceeded as they would reduce the useful life of the lamps or cause deterioration.

## 3- Installation and Assembly:

Possible ways to assemble it: The suspension yoke (1) can be adapted by means of the C clamp accessory to hang the projector from pipes up to 2" (51mm); or through the 28mm spigot accessory or adapter socket 16mm to stand.

**WARNING: The installation, maintenance, repair and replacement of the components for this product must be only made by qualified personnel and in compliance with the safety standards in full force and effect in the country where the product is used.**



**WARNING: The use of safety cables is obligatory when installing the projector, which must be fixed by means of the safety cable as a second support.**  
**The safety cable is supplied as standard accessory and is part of the projector.**

### Instructions for using and fixing the safety cable or chain

Extend the safety cable and link one of its ends wrapping the projector yoke and the pipe or element where the projector is fixed, usually by means of the "C" clamp accessory. The ends of the safety cable are joined by means of a connection with a safety clip.

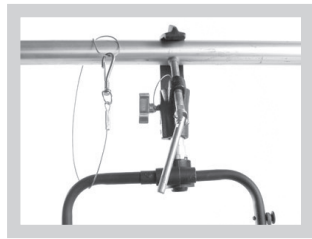
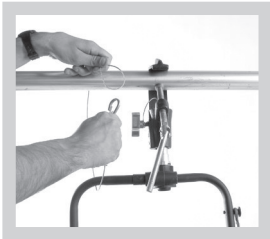

The safety cable must link the projector yoke with the pipe to which the projector is fixed by means of a C clamp, model 45-42 or model 45-43.

The projector also has other fixing and support places for the safety cable, in the same body, to be used in case the projector needs to be hung in different situations and manners.



**WARNING: DO NOT INSTALL THE PROJECTOR ON EASILY INFLAMMABLE SURFACES.**  
**The label on the projector indicates the minimum distance that must be kept from any easily inflammable surface.**



**WARNING: The luminaire has been designed for INTERNAL USE.**  
**It must be installed in dry places.**

**Protecting metal shield (Wire guard):** The safety standards indicate that a metal wire shield for protection must be mounted at the front of the projector in order to prevent large pieces of glass from falling when a lens or lamp breaks. The metal shield must have a 25mm x 25mm mesh.

**Accessories:** The accessories available for this equipment are listed in the catalogue and in the price list. The accessories can be mounted by inserting them into the guides for that purpose (2).

### 4- Changing the lamp

For safety reasons always disconnect the equipment from the mains or switches before opening it to change the lamp. Open the unit to have access to the lampholder and insert the lamp into the socket taking care not to touch the glass.

The quartz envelope of all tungsten halogen lamp will remain hot for a considerable period of time after switching off, or after filament failure, and are dangerous to handle in this condition. Allow to cool for at least five minutes before removing the lamp using a dry cloth.

It is not necessary to change the position of the projector to remove the lamp, so the optical adjustment of the projector may remain unchanged.

### 5- Correct position of the projector:

The projector uses a halogen lamp with tungsten filament. In order to prevent short useful life of the lamp or an early failure, it is essential for the projector to be always mounted horizontally on its yoke and with the base of the lamp facing downwards. The beam angle of the device must not be higher than 90° below the horizontal line. ↑

### 6- Focusing the projector

Using the knobs (3) on the side of the projector it is possible to loosen the position in which the projector is fixed, change the inclination and lock it again in the desired position. In the same way, the projector is rotated with respect to its vertical axis by loosening the screw located in the hole of yoke that connects it to the C clamp or to the stud.

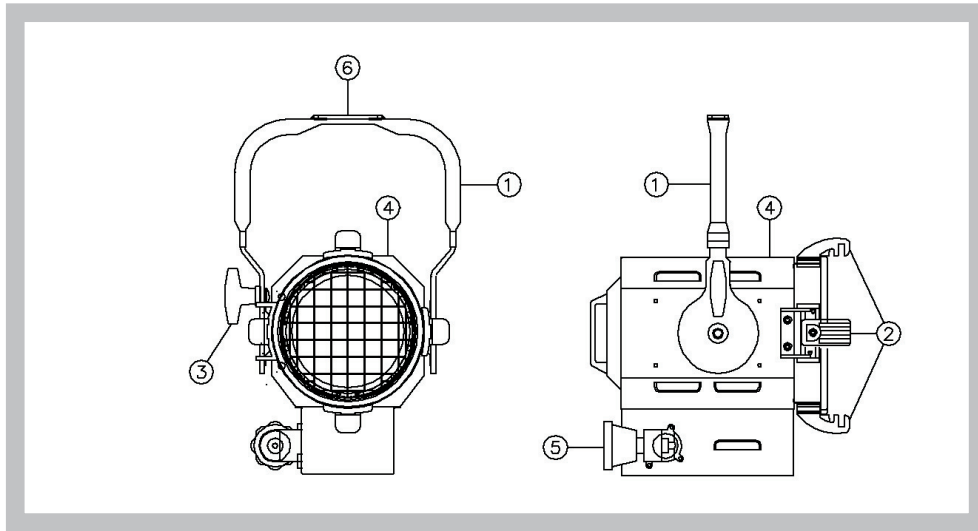

### 1- Projector description

(Corresponds to numbers shown in the figure)

- 1** Suspension yoke
- 2** Accessory guide with retaining clip
- 3** Knob for adjusting projector inclination
- 4** Hole for anchorage of safety cable
- 5** Knob for adjusting the beam angle
- 6** Hole for locking "C" clamp or place the projector on a stand.

### 8- Cleaning

For a better performance of the projector both the lens and the reflector must be kept as clean as possible. Disconnect the projector from the mains, open the unit, and both the lens and reflector can be cleaned with a soft cloth dampened (not soaked) with a 1:1 mixture of alcohol and water to wipe both the reflector and the lens clean.

### 9- Types of lamps to be used:

Fresnel Model	Coding Ansi	Brand Coding	Watts	Volts	Socket	Useful life hours	°Kelvin
50-01	CP81	CP81 GE	300	220	GY 9.5	150	3200
50-02	CP89	CP89 GE	650	220	GY 9.5	150	3200
50-03	CP40	CP40 FKJ Osram	1000	220	G22	400	3200
50-04	CP41	CP41 FKK Osram	2000	220	G38	400	3200
50-05	CP29	CP29 Osram	5000	220	G38	400	3200
50-05	DPY	DPY GE	5000	220	G38	500	3200

### 10- Maintenance:

**WARNING: REPLACE THE LAMP AND/OR LENS IF THEY ARE VISIBLY DAMAGED**

**WARNING: REPLACE THE PROTECTING METAL SHIELD (WIRE GUARD) IF VISIBLY DAMAGED**

The repair must be made by a qualified technician. Use original DEXEL spare parts to replace damaged parts.

The unit must be serviced at least once a year in order to control the electric and mechanic parts.